

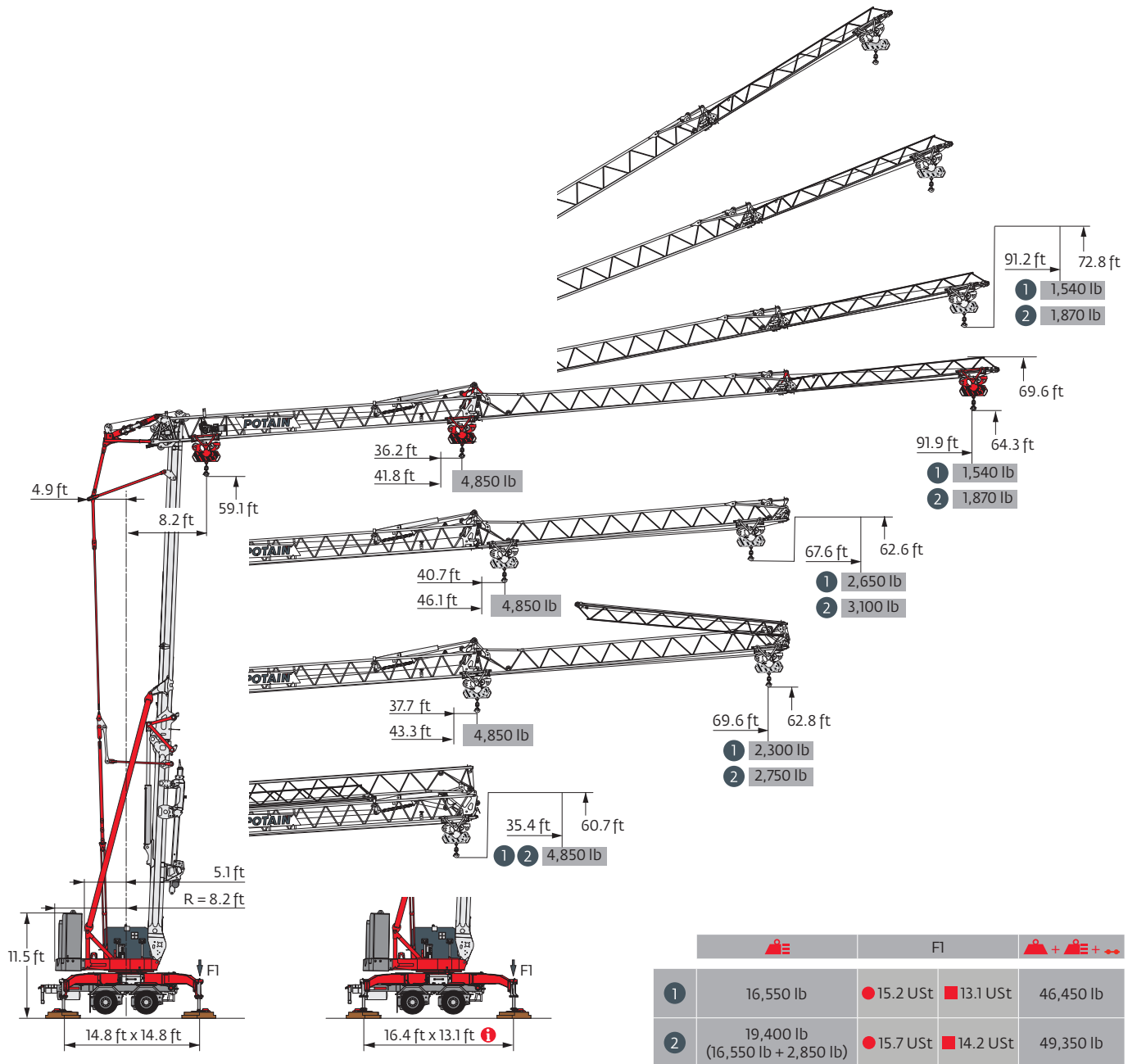

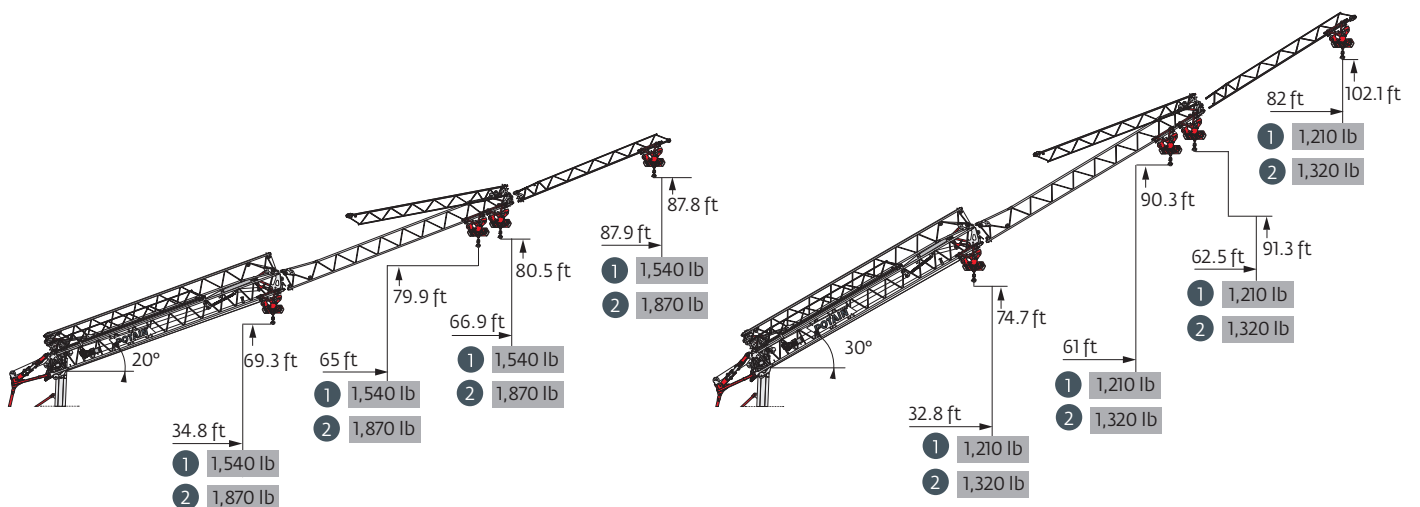

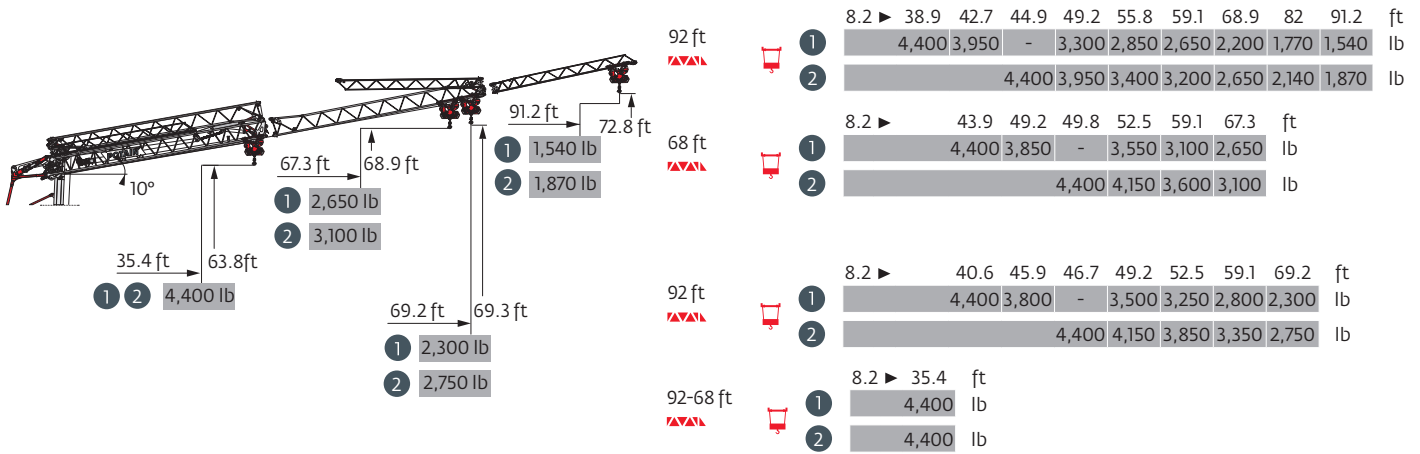

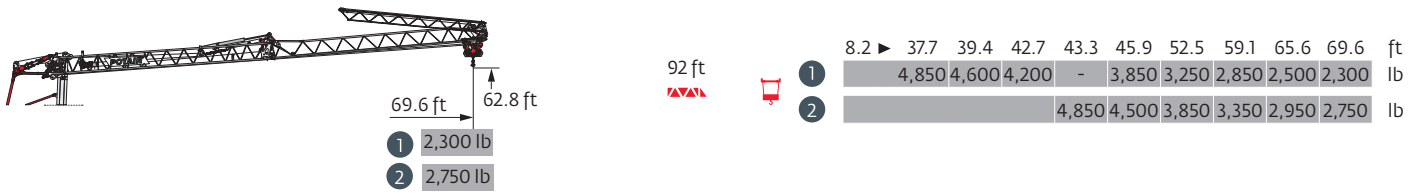

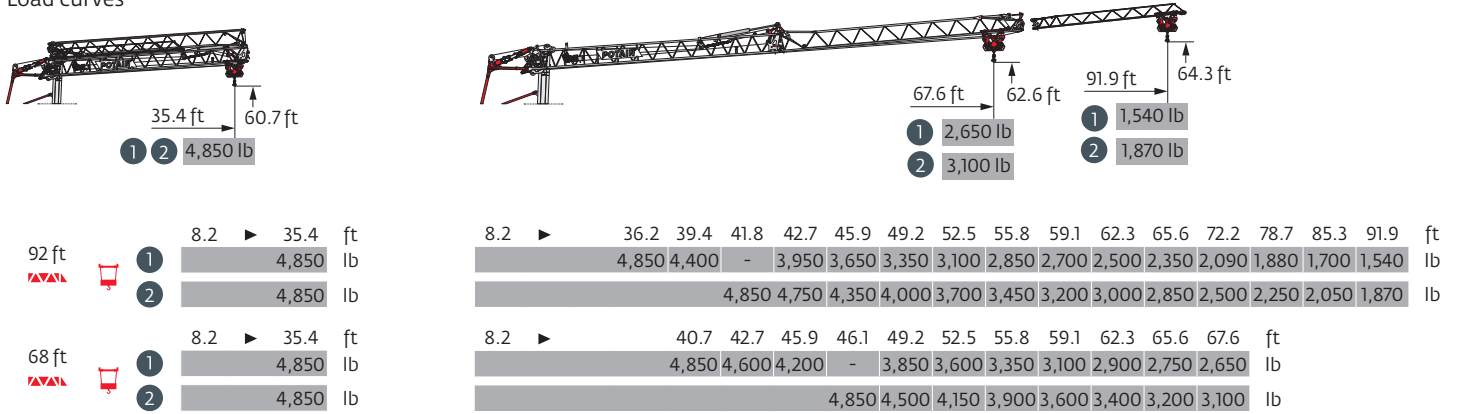

Hup M 28-22





Load curves



Mechanisms

230 V - 60 Hz 480 V - 60 Hz								hp	kW	
	10 LVF 11 Optima	230 V 	fpm	5	16	34	39	56	3.3	2.4
		20 A 	lb	4,850	4,850	2,200	1,870	1,210		
		230 V 	fpm	5	30	61	72	98	5.2	3.8
		32 A 	lb	4,850	4,850	2,200	1,870	1,210		
		480 V 	fpm	5	71	126	138	161	10	7.5
			lb	4,850	4,850	2,200	1,870	1,210		
	2 DVF 4 Optima	fpm	6	92	115	135	156	2	1.5	
		lb	4,850	4,850	2,400	1,320	440			
	HPS 131	rpm	0 → 0.8					4	3	

 IEC 60204-32	kVA
230 V (+6% -10%) 60 Hz	230 V 20A : 4.6 kVA 230 V 32A : 7.4 kVA
480 V (+6% -10%) 60Hz	480 V : 13 → 9 kVA 

10 LVF 11 Optima

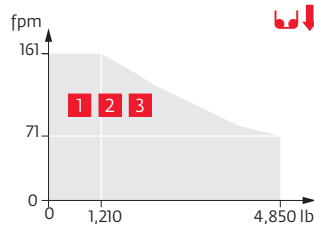
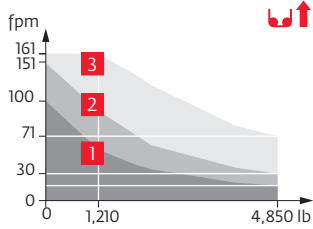

Erection

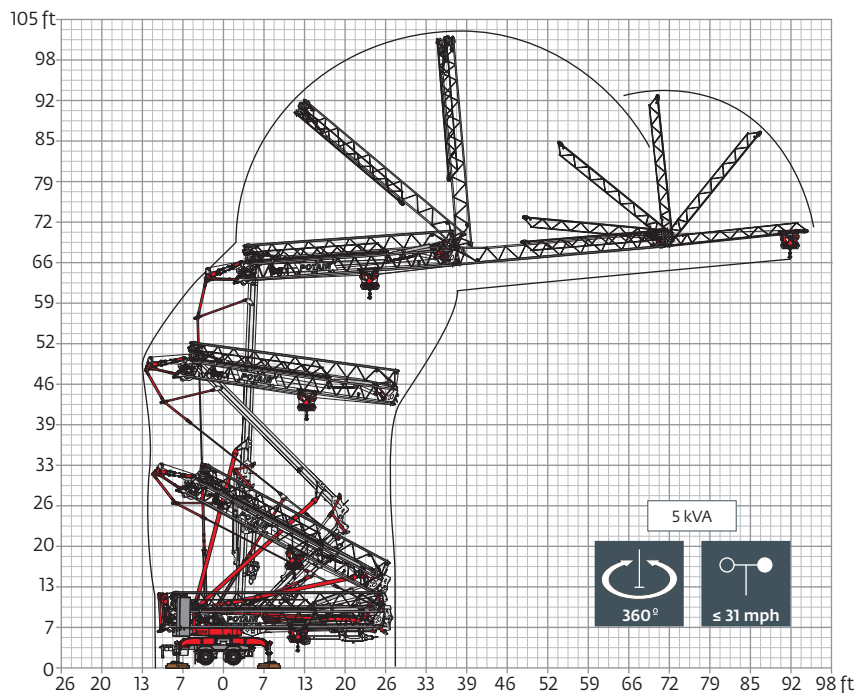

Transport

NORTH AMERICAN HIGHWAY AXLE

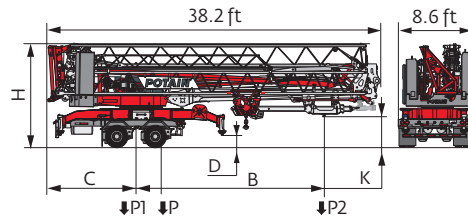

	mph	Weight without load, without ballast, without transport axles, with max. jib and standard height	B (ft)	C (ft)	D (ft)	H (ft)	K (ft)	P (lb)	P1 (lb)	P2 (lb)
TS014/S2-054A	50	16,550 lb	21.6	10.1	1.3	11.9	3.8/4	46,450	43,250	3,200
	50	19,400 lb	21.6	10.1	1.3	11.9	3.8/4	49,350	42,670	6,680

- Rear slewing radius
- Reactions in service
- Reactions out of service
- Standard equipment
- Options
- Weight without load, without ballast, without transport axles, with max. jib and standard height
- Total ballast weight
- Transport axles
- Transport of crane with full ballast
- Power Control Function: winch speeds adapted to the available power
- Hoisting
- Trolleying
- Slewing
- Required power
- Consult us

This commercial document is not legally binding. For any technical information, please refer to the corresponding instructions.

